



Memo

TO: Committee of the Whole
FROM: Ed Andrews, Public Works Director
DATE: June 8, 2018
SUBJECT: Discussion of Combined Driveway Standard
for existing rehabilitation requests

The following memorandum was presented and discussed with the Public Works Committee (PWC) on 6-4-18. It was the consensus of the PWC to advance this discussion to the Committee of the Whole.

A recent request from Roger Harter of 511 Monroe Street wishes to construct ½ of a combined apron. Current conditions are shown below.



Current standards do not provide for a combined driveway, an excerpt of City Standard 015 is shown below and a complete copy attached herewith.

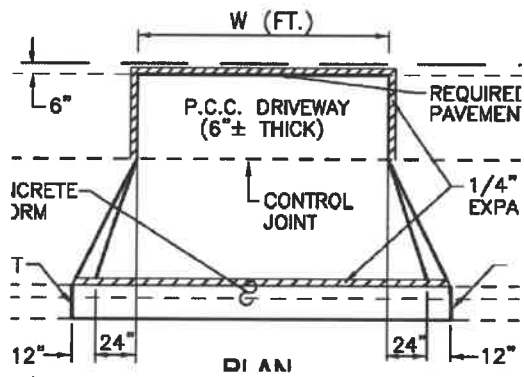

Staff has taken the opportunity to lay out City Standard 015 at the area in question and finds that a standard installation is feasible, but the Owner feels that a combined entrance is more fitting.



Since there currently is no combined standard, the request to establish one and how to limit its use is being presented for discussion with Committee. PWC felt that a limited use standard could be acceptable, limiting the width to the current residential standard of 30' (15' per home served) and making it clear that it would only apply to existing shared driveways. This would help insure that no new developments would adopt such a detail.

DRIVEWAY ENTRANCE DETAIL FOR CURB OPENINGS WITH SIDEWALK/PARKWAY

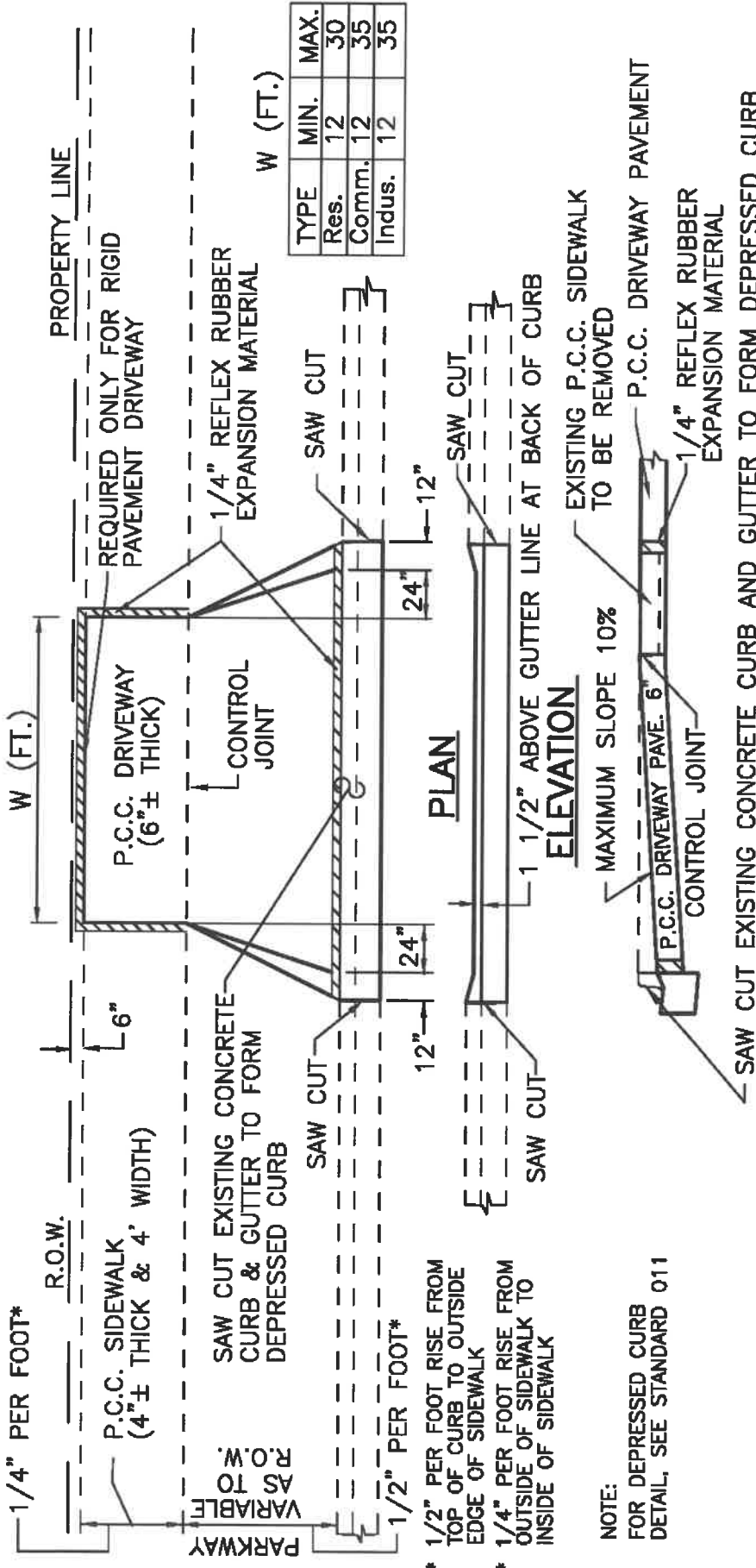

GENERAL NOTES:

1. CONSTRUCTION SHALL BE IN ACCORDANCE WITH THE STATE OF ILLINOIS "STANDARD SPECIFICATIONS FOR ROAD AND BRIDGE CONSTRUCTION" CURRENT EDITION AND SUPPLEMENTAL SPECIFICATIONS, UNLESS OTHERWISE DIRECTED BY THE CITY ENGINEER.
2. 2% CROSS SLOPE MUST BE MAINTAINED THROUGH SIDEWALK PORTION OF DRIVEWAY.
3. SIDEWALK AND CURB & GUTTER SHALL BE SAWED AT THE BEGINNING AND END OF THE REMOVAL SECTION.
4. WHERE NO SIDEWALK EXISTS, THE DRIVE SHALL BE CONSTRUCTED AS SHOWN TO ACCOMMODATE FUTURE SIDEWALK.
5. WHEN DRIVEWAY OPENING IS PROVIDED AT THE TIME OF CURB CONSTRUCTION, CONTRACTION JOINTS SHALL BE PLACED AT THE LOCATION OF THE SAW CUTS AS SHOWN.
6. ALL SAW CUTS MUST BE A MINIMUM OF 1" DEEP.
7. IN NO CASE SHALL CURB OPENING BE CONSTRUCTED BEYOND EXTENDED PROPERTY LINE OF ADJOINING PROPERTY.

SECTION

SAW CUT EXISTING CONCRETE CURB AND GUTTER TO FORM DEPRESSED CURB

City Of Washington

CONSTRUCTION STANDARD

DATE:	STANDARD NO.
DEC. 1999	015